

# Recycled Parts Request: SPORT UTILITY VEHICLE FORM

Date: \_\_\_\_\_

To: \_\_\_\_\_

Contact Person: \_\_\_\_\_

Phone #: \_\_\_\_\_

Year: \_\_\_\_\_

Model: \_\_\_\_\_

P.O. #: \_\_\_\_\_

From: Parsons Auto Parts L.L.C

Ph: 614-443-7451 Fax: 614-443-4006

Fax #: \_\_\_\_\_

Make: \_\_\_\_\_

VIN #: \_\_\_\_\_

Build Date: \_\_\_\_\_

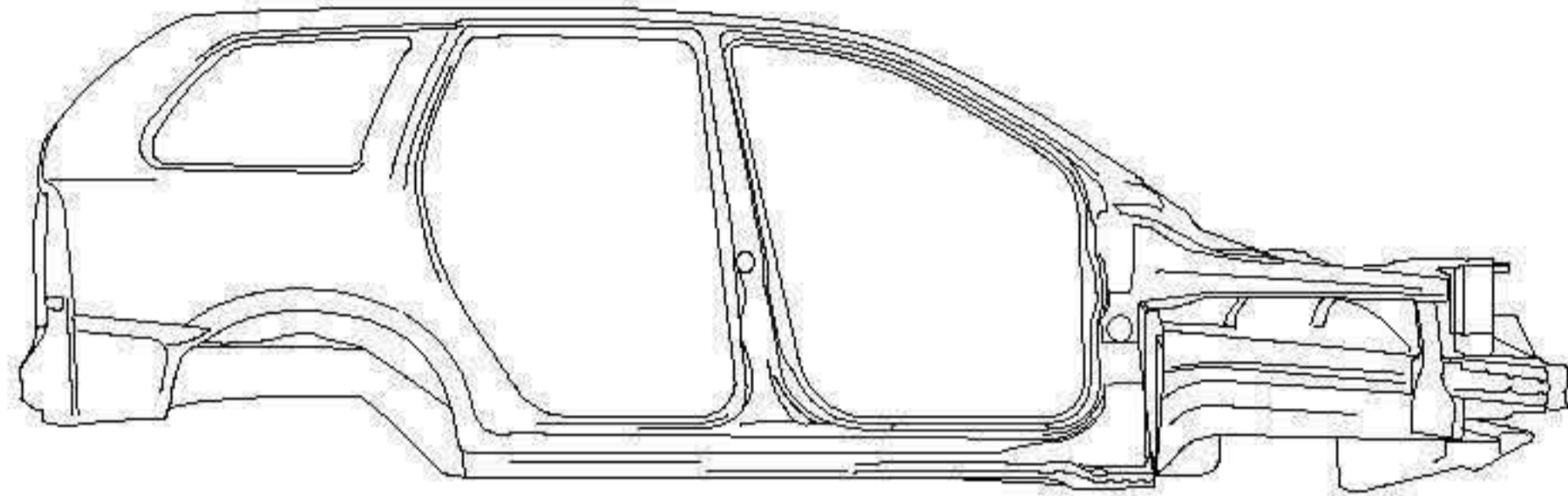

PASSANGER SIDE

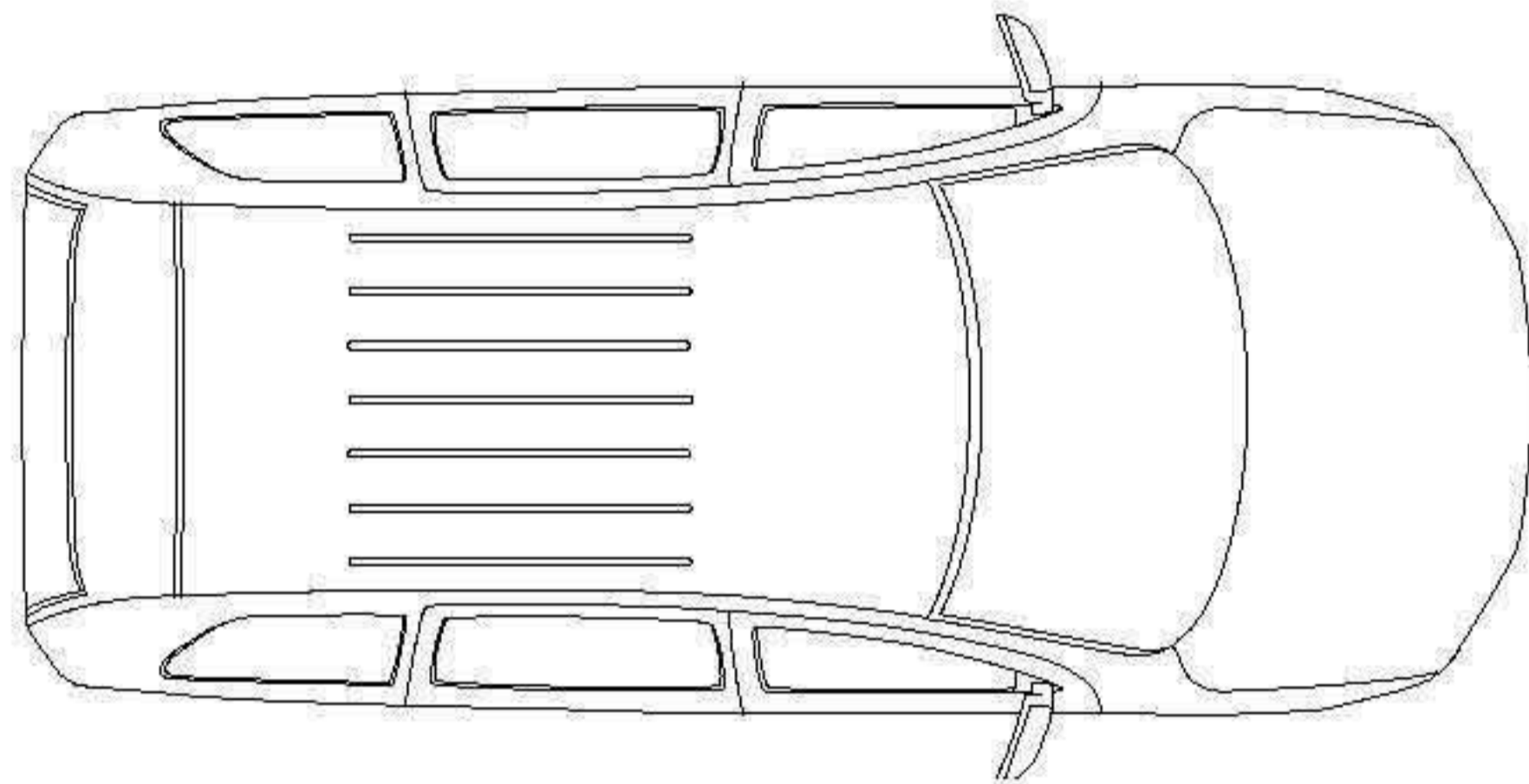
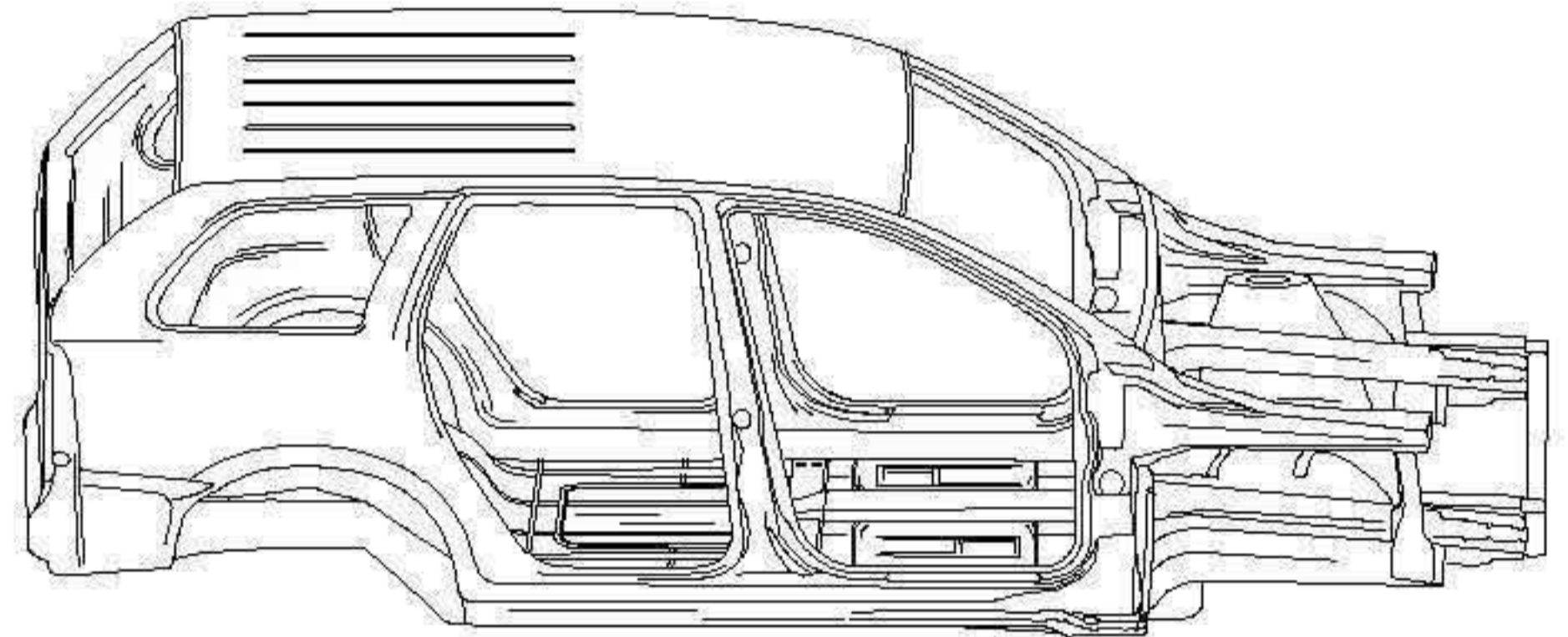

TOP VIEW

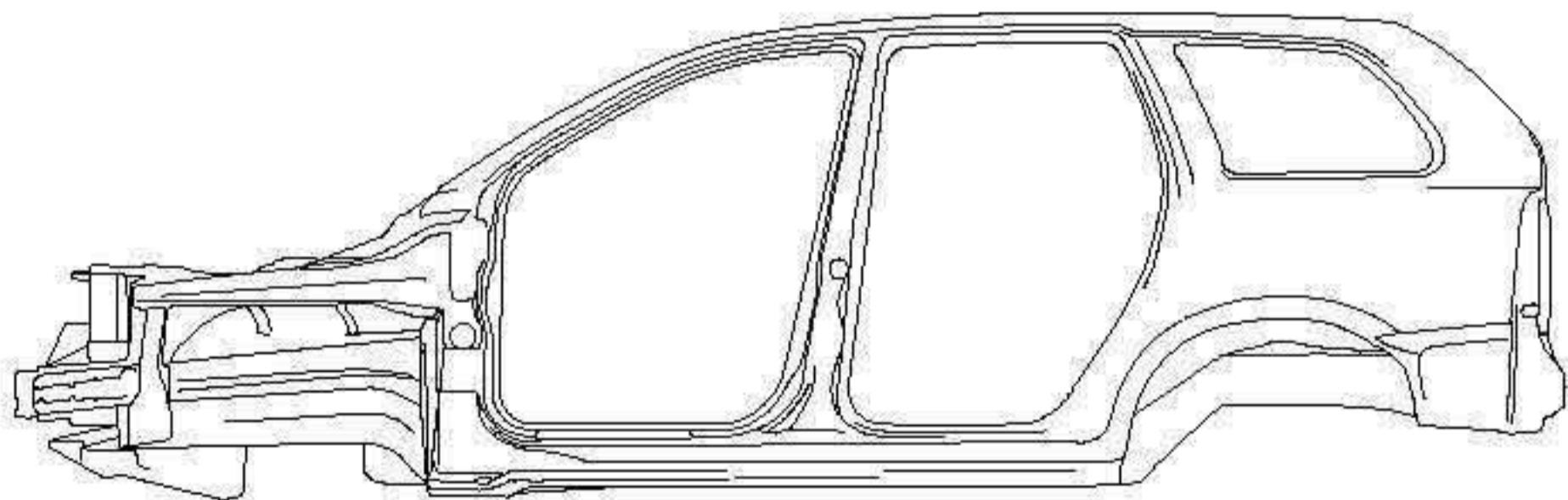

DRIVER SIDE

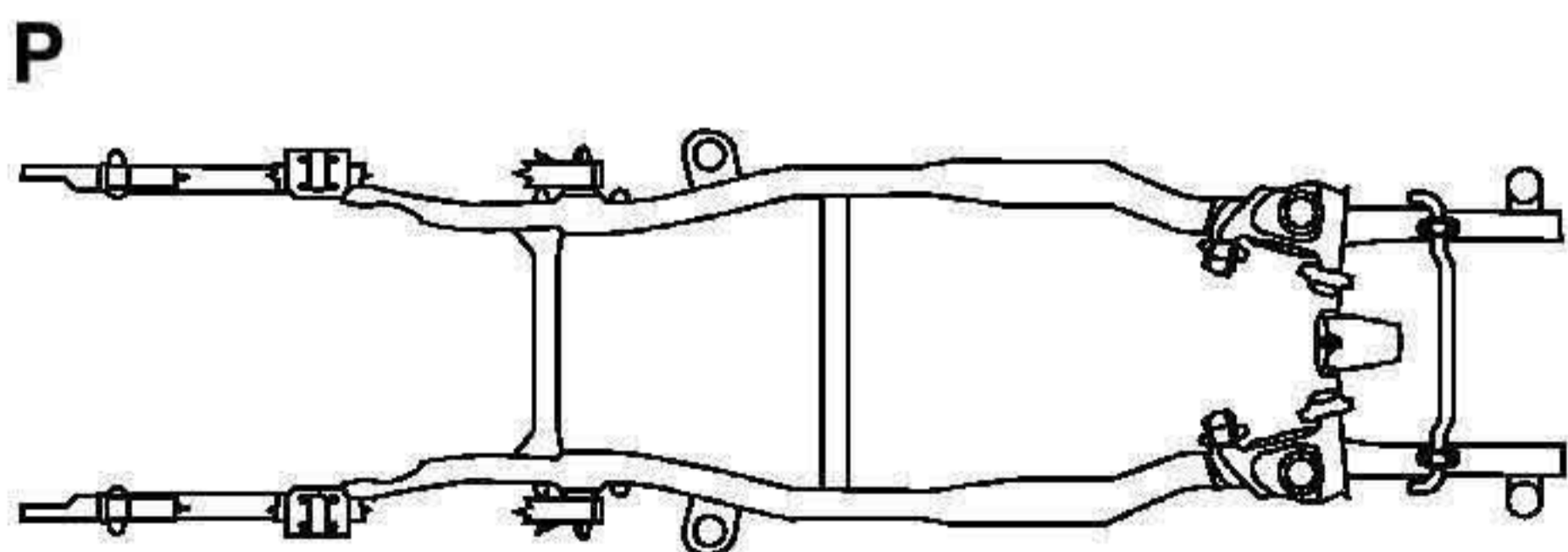

P  
D  
TOP VIEW

Please use the area below for a detail of cut instructions:

Notes:

\_\_\_\_\_  
\_\_\_\_\_  
\_\_\_\_\_  
\_\_\_\_\_  
\_\_\_\_\_  
\_\_\_\_\_  
\_\_\_\_\_  
\_\_\_\_\_  
\_\_\_\_\_